

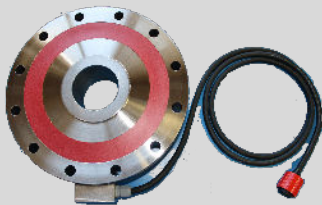

## Submersible Load Cell Catalog

- Tension Link Load Cells
- Pancake Load Cells
- S Beam Load Cells
- Multi Axis Load Cells
- Reaction & Rotary Torque Sensors
- Custom Applications



[www.sensing-systems.com](http://www.sensing-systems.com)

[info@sensing-systems.com](mailto:info@sensing-systems.com)

+1 (508) 992-0872



## TABLE OF CONTENTS

|   |           |
|---|-----------|
| <b>INTRODUCTION</b>   | <b>3</b>  |
| Availability  | 3         |
| Applications  | 3         |
| Testing   | 3         |
| <b>SUBMERSIBLE TENSION LINK LOAD CELLS</b>                    | <b>4</b>  |
| Standard Product Specifications                               | 5         |
| Standard Product Outline Geometry - 1,000 lbf to 5,000 lbf    | 6         |
| Standard Product Outline Geometry - 10,000 lbf to 20,000 lbf  | 7         |
| Standard Product Outline Geometry - 50,000 lbf to 100,000 lbf | 8         |
| <b>SUBMERSIBLE PANCAKE LOAD CELLS</b>                         | <b>9</b>  |
| Standard Product Specifications                               | 10        |
| Standard Product Outline Geometry - 1,000 lbf to 200,000 lbf  | 11        |
| <b>SUBMERSIBLE S BEAM LOAD CELLS</b>                          | <b>12</b> |
| Standard Product Specifications                               | 13        |
| Standard Product Outline Geometry - 100 to 20,000 lbf         | 14        |
| <b>SUBMERSIBLE MULTI AXIS LOAD CELLS</b>                      | <b>15</b> |
| <b>SUBMERSIBLE TORQUE SENSORS</b>                             | <b>15</b> |
| Reaction Torque Sensors                                       | 15        |
| Rotary Torque Sensors   | 15        |
| <b>CUSTOM SUBMERSIBLE &amp; UNDERWATER SOLUTIONS</b>          | <b>15</b> |
| <b>TESTING SERVICES</b>                                       | <b>16</b> |
| NIST Traceable Calibrations                                   | 16        |
| Pressure Vessel Testing                                       | 16        |
| <b>SIGNAL CONDITIONING AMPLIFIER OPTIONS</b>                  | <b>16</b> |
| External Signal Conditioning Amplifier                        | 16        |
| Internal Signal Conditioning Amplifier                        | 16        |
| <b>ADDITIONAL INSTRUMENTATION &amp; ACCESSORIES</b>           | <b>17</b> |
| Digital Display & Readout Options                             | 17        |
| Digital & Serial Output Options                               | 17        |



## INTRODUCTION

Sensing Systems specializes in submersible load cells and torque sensors for use in seawater, pressure vessel, research and development, outdoor, and all other submersible or high pressure applications. Through specialized design and instrumentation techniques, Sensing Systems offers a broad range of load cells and torque sensors specifically tailored for use at sea level, a few feet underwater all the way up to 23,000 feet or 10,000 psi operating pressure. Customized electrical connections, integral cables, signal conditioning amplifiers, and digital displays are all available options. Each transducer and any additional options are provided to the customer with an ASTM E4 or E264 NIST traceable calibration and certificate. All submersible load cells and torque sensors are designed, manufactured, and calibrated at our headquarters in Massachusetts, USA. Sensing Systems measurement products and testing services are accredited to ISO 9001:2015 and ISO/IEC 17025:2017.

### Availability

Sensing Systems manufactures all submersible load cells and torque sensors to order due to the custom nature of each application. Standard designs for the most common requirements are below. To an extent and within technical practicality, all of these designs can be modified and customized to meet exact customer requirements. If required, a submersible load cell or torque sensor can ship from the factory within one week or sooner. Consult the factory with your application requirements and we can provide current pricing and lead time.

### Applications

Sensing Systems has supplied submersible load cells and torque sensors across the globe to numerous naval programs, oceanographic research institutions, the oil industry, research and development facilities, and the general marine industry. Typical force measurements include rigging, anchoring, and towing forces. Torque sensors may be used to acquire operating torques for winches and submersible pumps and motors.

### Testing

Sensing Systems is accredited to ISO/IEC 17025:2017 and offers a full range of calibration services. At a minimum, all load cells and torque sensors are calibrated using NIST traceable standards per ASTM E4 or ASTM E264. Supplemental calibration or test data can be provided upon request. Additionally, all load cells and torque sensors undergo a 5 point electrical test prior to leaving the factory. All calibration and electrical data are provided on a calibration certificate shipped with each load cell or torque sensor. If required, calibrations may be performed in accordance with other industry standards or to customer specific requirements. Depending on the end user's application requirements, the option to pressure test individual load cells or torque sensors is available.



## **SUBMERSIBLE TENSION LINK LOAD CELLS**

Sensing Systems manufactures submersible tension link load cells designed to measure in line tension forces at depths ranging from a few feet underwater all the way to 23,000 feet submerged. Standard designs exist for 1,000 lbf up to 100,000 lbf. For capacities beyond 100,000 lbf, please contact Sensing Systems directly with your request and general requirements. An applications engineer will provide a design specific to your application. Sensing Systems has the capacity to design, manufacture, and test submersible tension link load cells up to 5,000,000 lbf capacity.

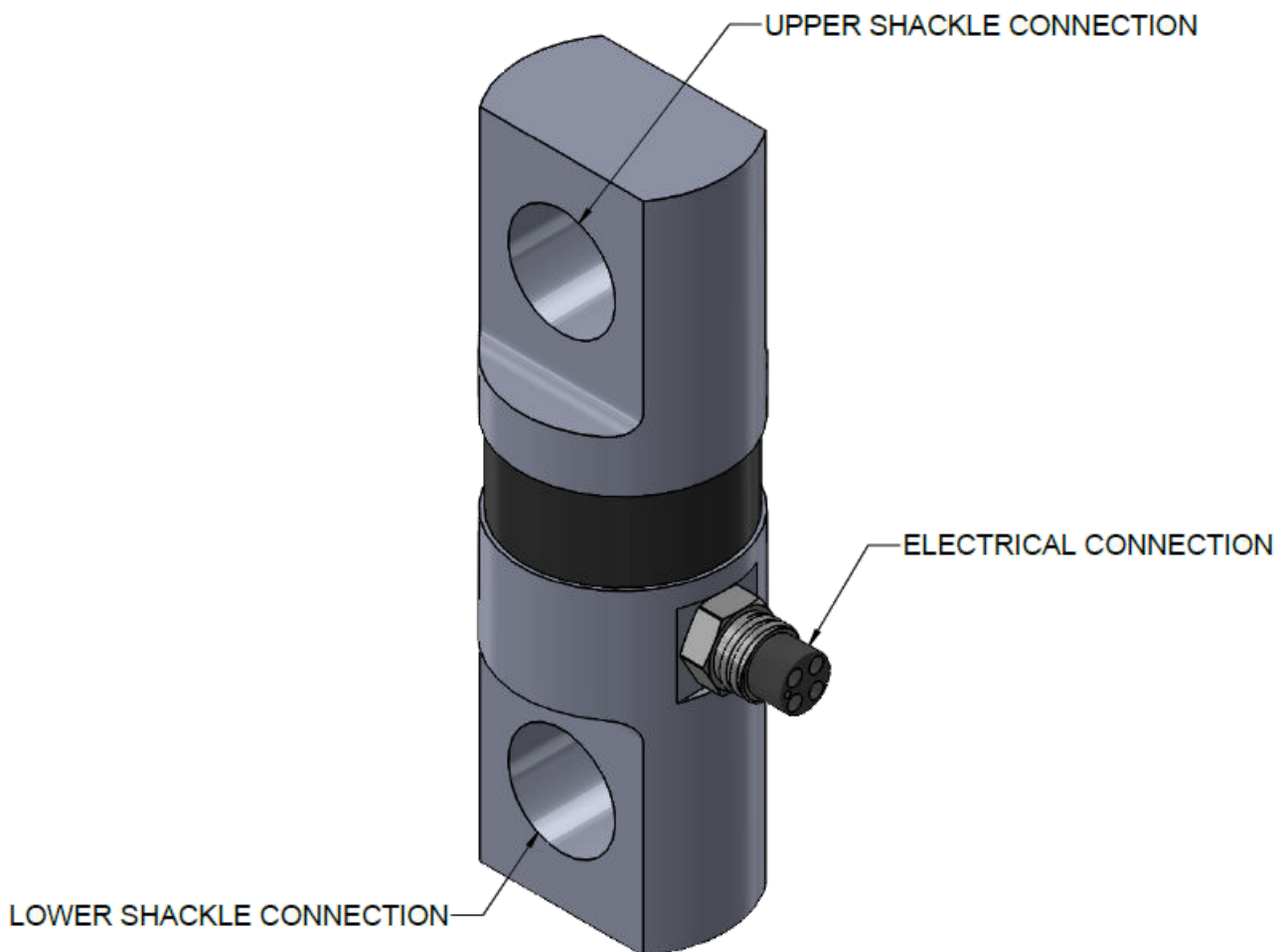

### **APPLICATIONS**

- Measure in-line anchor or mooring tension forces
- Monitor submersible equipment attachment forces

**SUBMERSIBLE TENSION LINK LOAD CELLS****Standard Product Specifications**

|  |  |
|--|--|
| Full Scale Capacity (FS)               | 1,000 to 100,000+ lbf                            |
| Material <sup>1</sup>                  | 17-4 PH Stainless Steel                          |
| Nominal Output Signal at Capacity (FS) | 2.0 mV/V   |
| Optional Amplified Output <sup>2</sup> | 0 to 5 VDC, 0 to 10 VDC, 4 to 20 mA              |
| Combined Error                         | ≤ 0.25% of FS                                    |
| Zero Balance Signal                    | ≤ 1.00% of FS                                    |
| Input & Output Resistance <sup>3</sup> | 350 Ω Nominal                                    |
| Excitation Voltage                     | 2 to 24 V  |
| Insulation to Ground                   | > 5 GΩ   |
| Safe Overload                          | 150% of FS                                       |
| Ultimate Overload                      | 300% of FS                                       |
| Operating Depth                        | Customer Specified                               |
| Sensor Material                        | 17-4 Stainless Steel                             |
| Electrical Connection <sup>4</sup>     | MCBH-4F Bulkhead Wet Mate Connector              |
| Calibration                            | NIST Traceable per ASTM E4, Certificate Provided |

<sup>1</sup> Titanium, Aluminum, and others available

<sup>2</sup> Requires additional internal or external signal conditioning amplifier

<sup>3</sup> Options ranging from 120 Ω to 10,000 Ω available

<sup>4</sup> Optional custom connector or integral cable available

Sensing Systems manufactures all submersible load cells to order and can customize almost all aspects of the product to meet the exact requirements of a specific application. If you are interested in discussing your application with an applications engineer, please contact us directly at [info@sensing-systems.com](mailto:info@sensing-systems.com) or (508) 992-0872.



**SUBMERSIBLE TENSION LINK LOAD CELLS**

**Standard Product Outline Geometry - 1,000 lbf to 5,000 lbf**

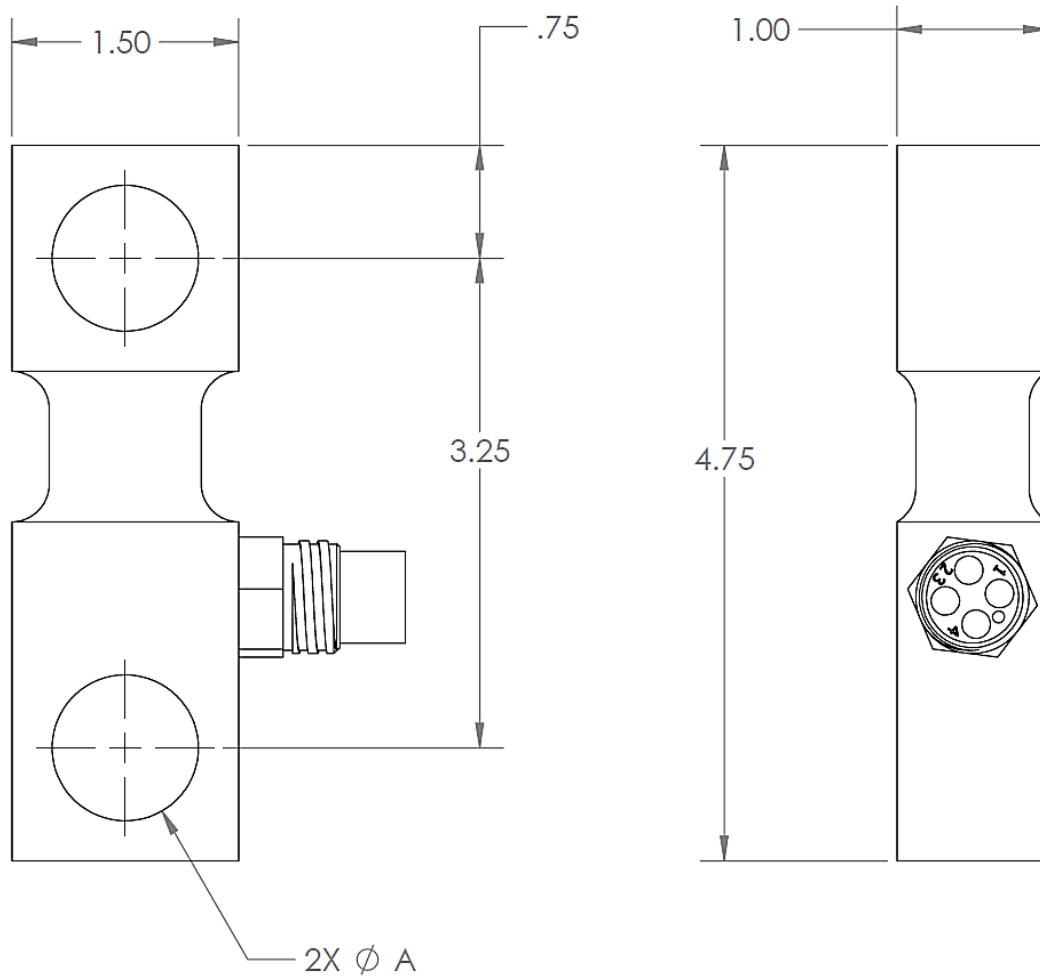

| Capacity (FS) | Shackle Pin Diameter (Nominal) | Diameter "A" |
|---------------|--------------------------------|--------------|
| 1,000 lbf     | 15/32"                         | 0.550"       |
| 2,000 lbf     | 1/2"                           | 0.580"       |
| 3,000 lbf     | 21/32"                         | 0.735"       |
| 5,000 lbf     | 29/32"                         | 0.985"       |



Note: The load cell is not designed to undergo torsional loads. It is the responsibility of the user to supply a suitable swivel or other device in series with the load cell if torsional loads will occur.

**SUBMERSIBLE TENSION LINK LOAD CELLS**

**Standard Product Outline Geometry - 10,000 lbf to 20,000 lbf**

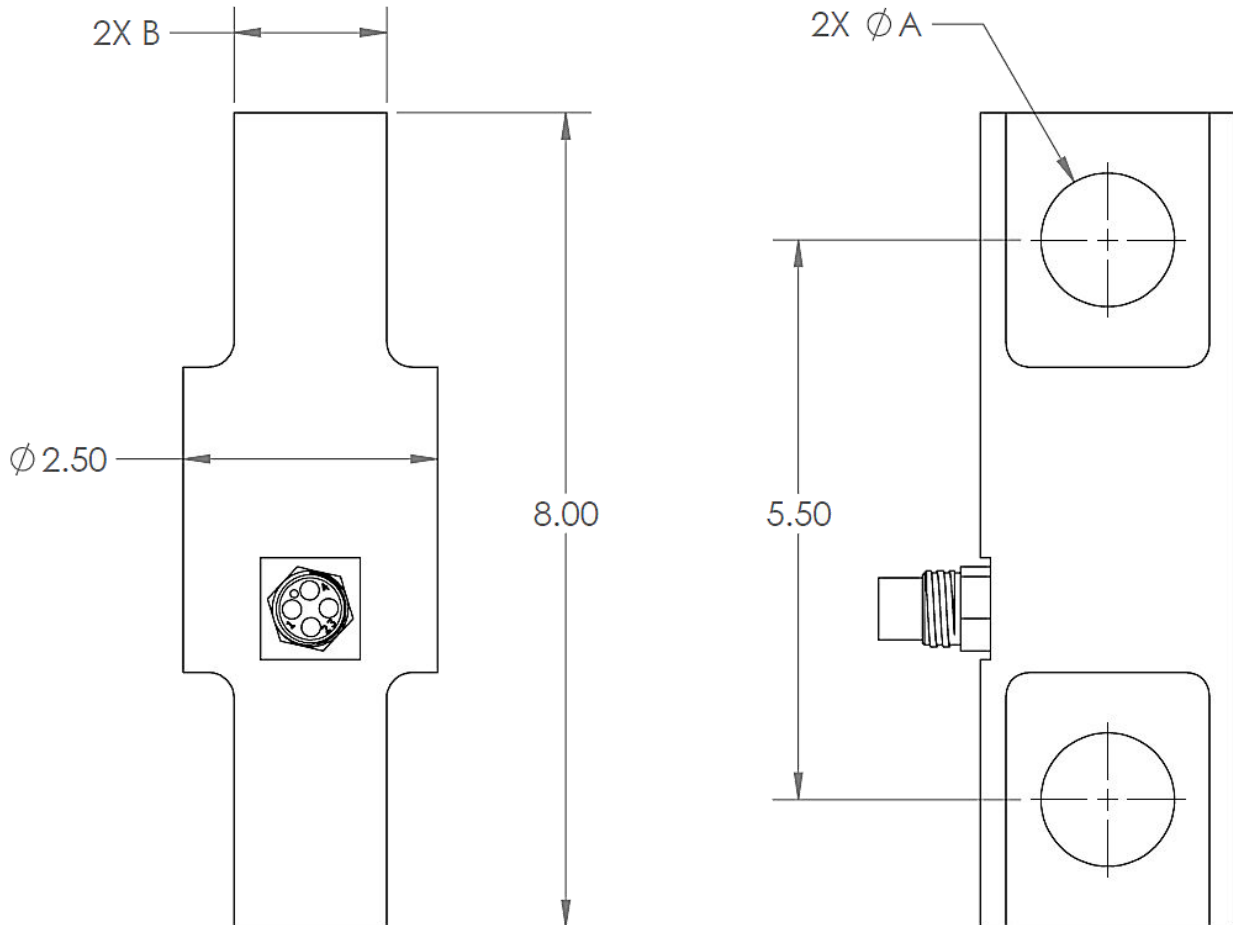

| Capacity (FS) | Shackle Pin Diameter (Nominal) | Diameter "A" | Width "B" |
|---------------|--------------------------------|--------------|-----------|
| 10,000 lbf    | 15/16"                         | 1.00"        | 1.00"     |
| 20,000 lbf    | 1-1/8"                         | 1.31"        | 1.75"     |

Note: The load cell is not designed to undergo torsional loads. It is the responsibility of the user to supply a suitable swivel or other device in series with the load cell if torsional loads will occur.



**SUBMERSIBLE TENSION LINK LOAD CELLS**

Standard Product Outline Geometry - 50,000 lbf to 100,000 lbf

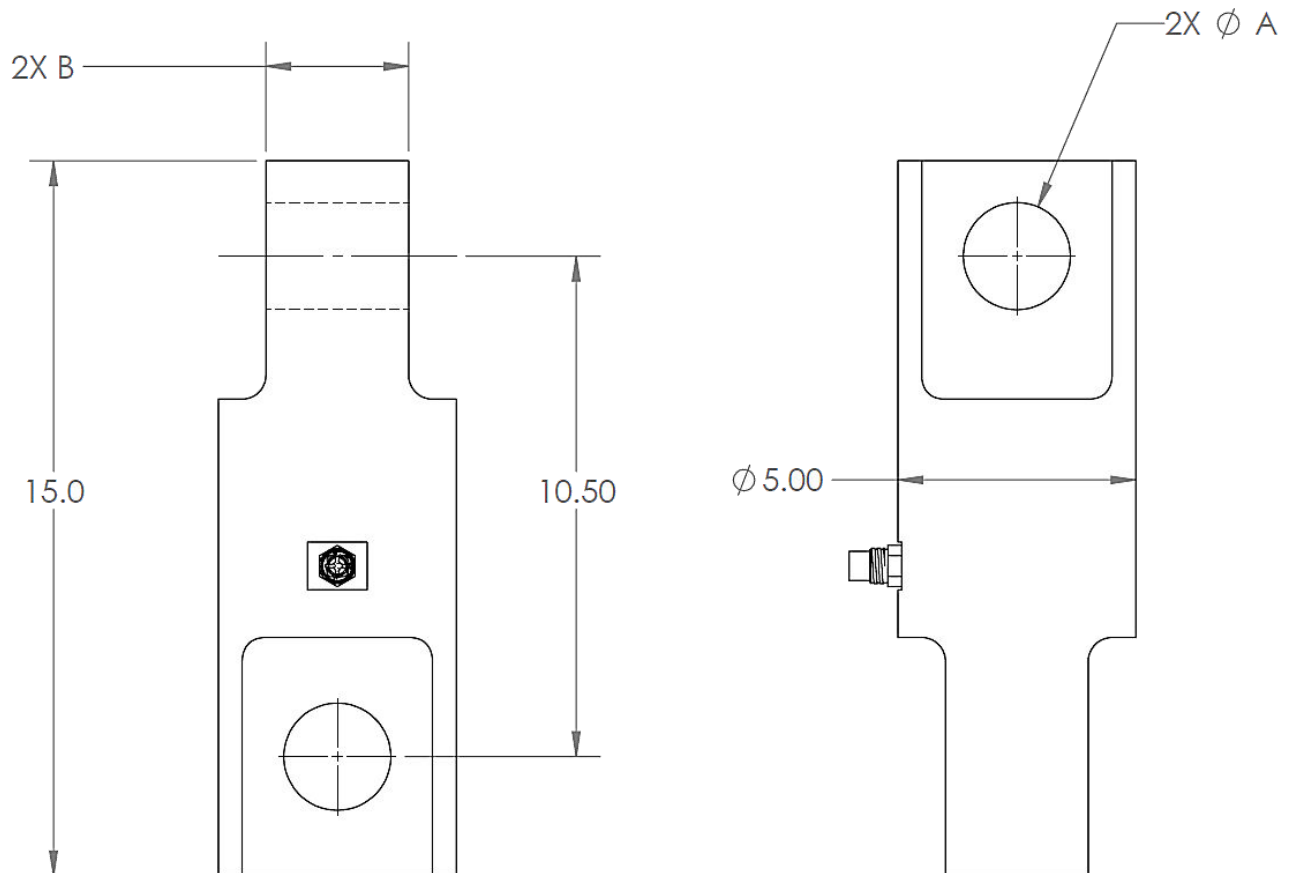

| Capacity (FS) | Shackle Pin Diameter (Nominal) | Diameter "A" | Width "B" |
|---------------|--------------------------------|--------------|-----------|
| 50,000 lbf    | 1-5/8"                         | 1.75"        | 2.75"     |
| 75,000 lbf    | 2-1/8"                         | 2.25"        | 3.00"     |
| 100,000 lbf   | 2-1/4"                         | 2.38"        | 3.50"     |

Note: The load cell is not designed to undergo torsional loads. It is the responsibility of the user to supply a suitable swivel or other device in series with the load cell if torsional loads will occur.



## **SUBMERSIBLE PANCAKE LOAD CELLS**

Sensing Systems manufactures submersible pancake style load cells designed to measure compression/tension forces at depths ranging from a few feet underwater all the way to 23,000 feet submerged. Standard designs exist for 1,000 lbf up to 200,000 lbf. For capacities beyond 200,000 lbf, please contact Sensing Systems directly with your request and general requirements. An applications engineer will provide a design specific to your application. Sensing Systems has the capacity to design, manufacture, and test submersible load cells up to 5,000,000 lbf capacity.

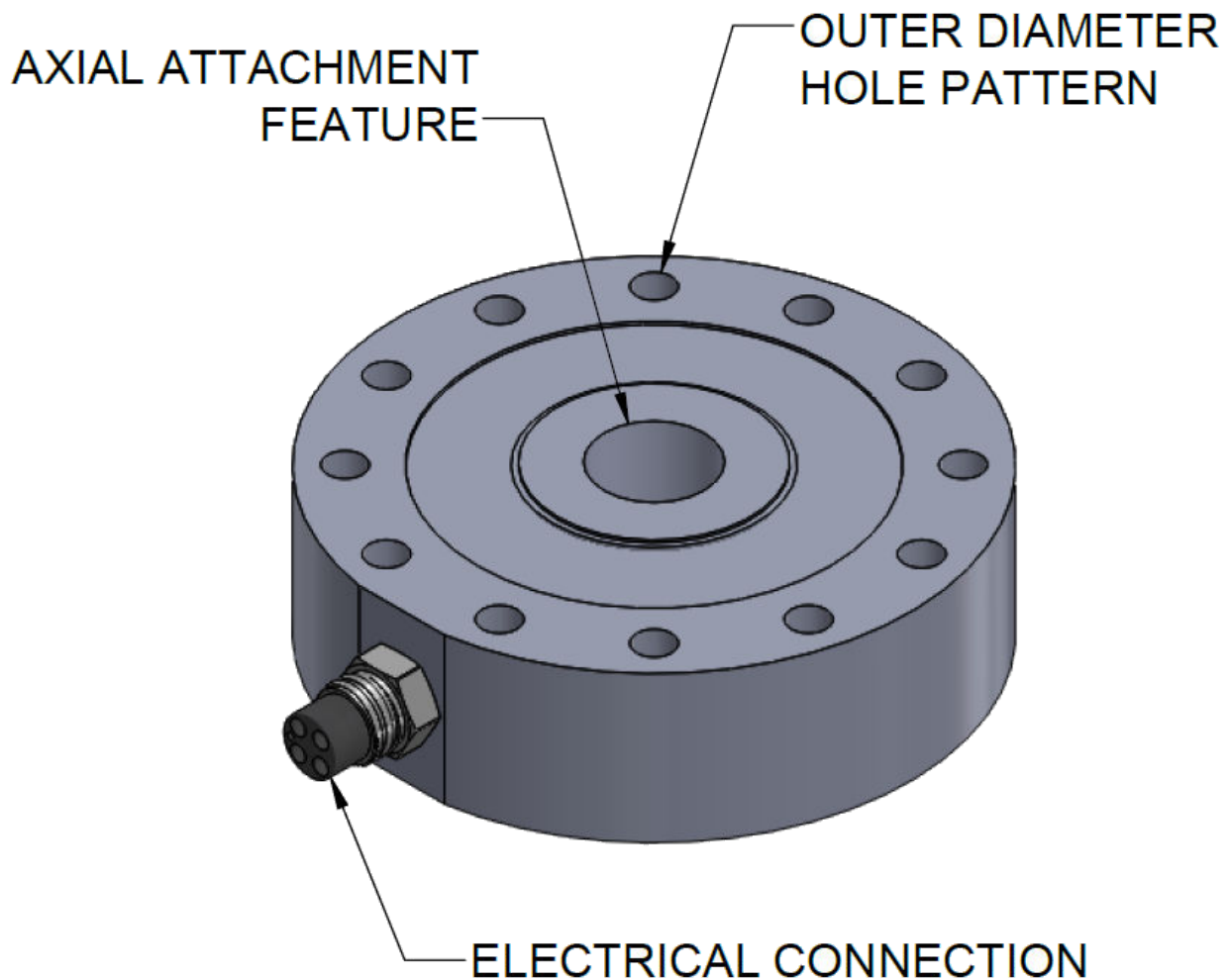

### **APPLICATIONS**

- Measure in-line anchor or mooring tension forces
- Monitor submersible equipment attachment forces

**SUBMERSIBLE PANCAKE LOAD CELLS****Standard Product Specifications**

|  |  |
|--|--|
| Full Scale Capacity (FS)               | 1,000 to 200,000+ lbf                            |
| Material <sup>1</sup>                  | 17-4 PH Stainless Steel                          |
| Nominal Output Signal at Capacity (FS) | 2.0 mV/V   |
| Optional Amplified Output <sup>2</sup> | 0 to 5 VDC, 0 to 10 VDC, 4 to 20 mA              |
| Combined Error                         | ≤ 0.25% of FS                                    |
| Zero Balance Signal                    | ≤ 1.00% of FS                                    |
| Input & Output Resistance <sup>3</sup> | 350 Ω Nominal                                    |
| Excitation Voltage                     | 2 to 24 V  |
| Insulation to Ground                   | > 5 GΩ   |
| Safe Overload                          | 150% of FS                                       |
| Ultimate Overload                      | 300% of FS                                       |
| Operating Depth                        | Customer Specified                               |
| Sensor Material                        | 17-4 Stainless Steel                             |
| Electrical Connection <sup>4</sup>     | MCBH-4F Bulkhead Wet Mate Connector              |
| Calibration                            | NIST Traceable per ASTM E4, Certificate Provided |

<sup>1</sup> Titanium, Aluminum, and others available

<sup>2</sup> Requires additional internal or external signal conditioning amplifier

<sup>3</sup> Options ranging from 120 Ω to 10,000 Ω available

<sup>4</sup> Optional custom connector or integral cable available

Sensing Systems manufactures all submersible load cells to order and can customize almost all aspects of the product to meet the exact requirements of a specific application. If you are interested in discussing your application with an applications engineer, please contact us directly at [info@sensing-systems.com](mailto:info@sensing-systems.com) or (508) 992-0872.



**SUBMERSIBLE PANCAKE LOAD CELLS**

Standard Product Outline Geometry - 1,000 lbf to 200,000 lbf

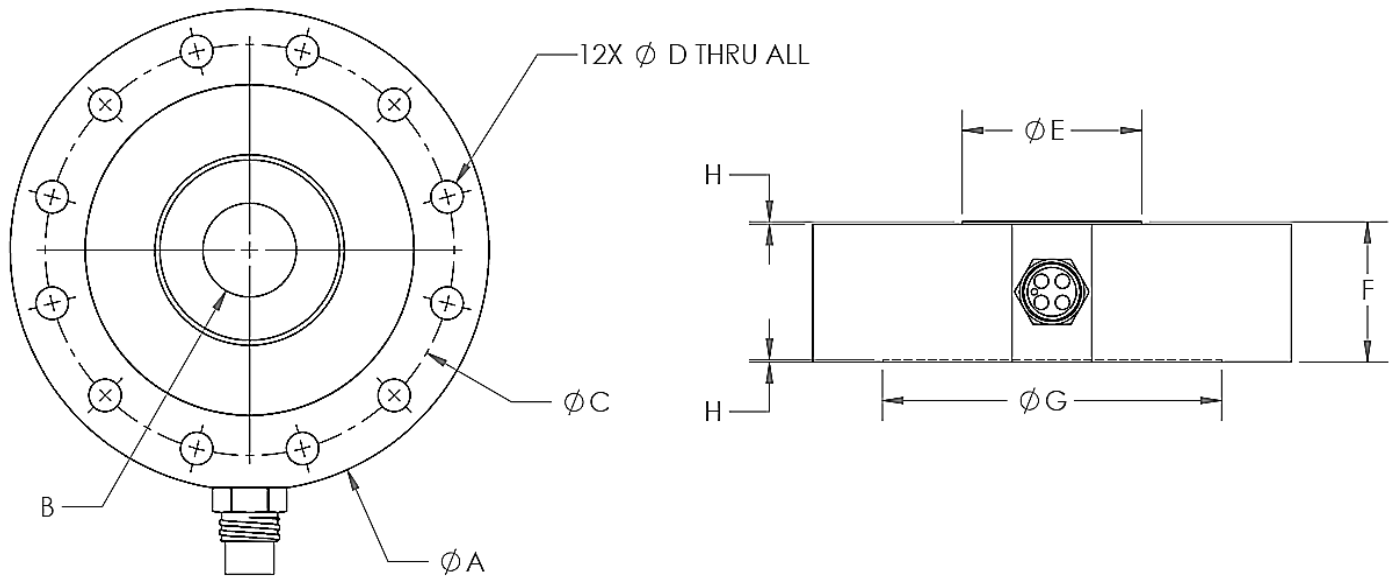

| Dimensions (inch)             | Full Scale Capacity (lbf) |           |             |             |             |            |
|-------------------------------|---------------------------|-----------|-------------|-------------|-------------|------------|
|                               | 1 to 2K                   | 5 to 10K  | 25 to 50K   | 70K         | 100K        | 200K       |
| A - Overall Dia.              | 4.25                      | 4.50      | 6.00        | 6.5         | 8.00        | 11.00      |
| B - Axial Thread              | 5/8" - 18                 | 3/4" - 16 | 1-1/4" - 12 | 1-1/2" - 12 | 1-3/4" - 12 | 2-3/4" - 8 |
| C - Mounting Hole Circle Dia. | 3.75                      | 3.75      | 5.13        | 5.38        | 6.50        | 9.00       |
| D - Mounting Hole Dia.        | 0.28                      | 0.28      | 0.41        | 0.41        | 0.53        | 0.78       |
| E - Axial Hub Dia.            | 1.25                      | 1.25      | 2.25        | 2.75        | 3.00        | 4.50       |
| F - Overall Height            | 1.40                      | 1.70      | 1.75        | 2.50        | 2.50        | 3.00       |
| G - Outerring Support Dia.    | 3.25                      | 3.00      | 4.25        | 4.38        | 5.00        | 7.00       |
| H - Loading Clearance Height  | 0.03                      | 0.03      | 0.03        | 0.03        | 0.03        | 0.03       |



## **SUBMERSIBLE S BEAM LOAD CELLS**

Sensing Systems manufactures submersible S beam style load cells designed to measure compression/tension forces less than 20,000 lbf for shallow depth applications. Standard designs exist for 100 lbf up to 20,000 lbf. For capacities beyond 20,000 lbf, please contact Sensing Systems directly with your request and general requirements. An applications engineer will provide a design specific to your application. Sensing Systems has the capacity to design, manufacture, and test submersible load cells up to 5,000,000 lbf capacity.

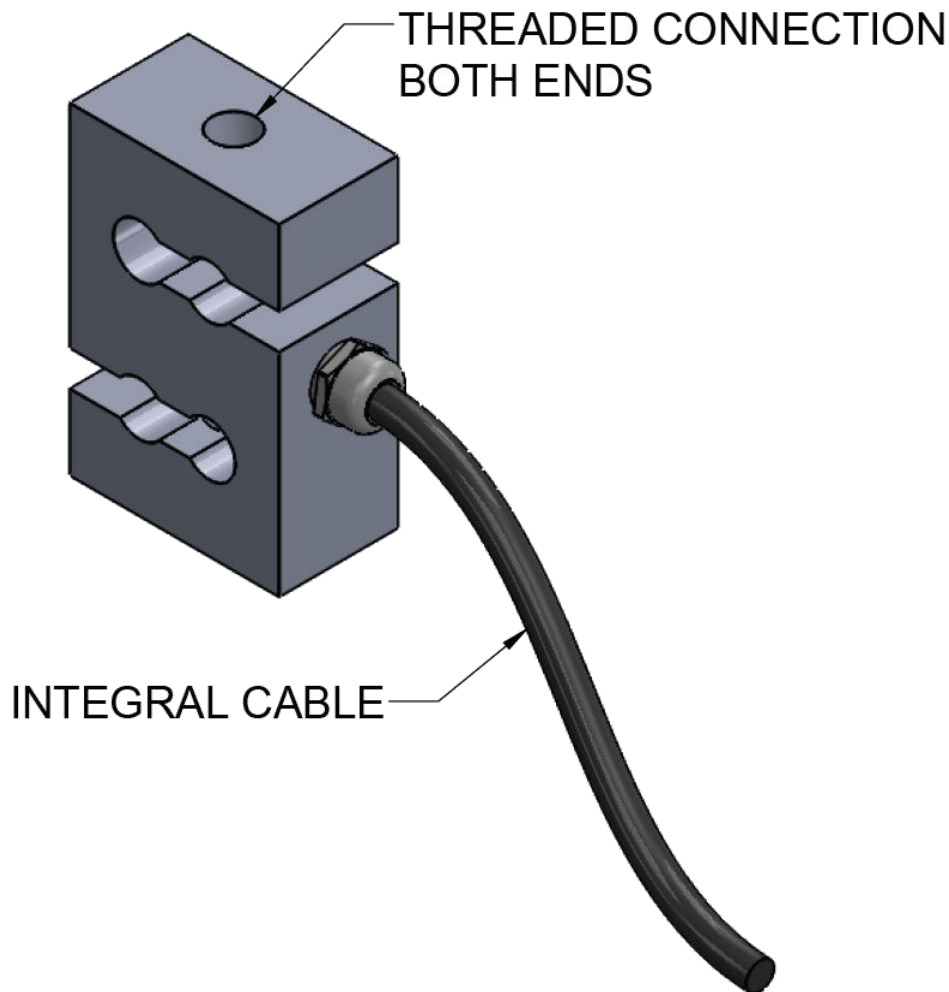

### **APPLICATIONS**

- Shallow water in-line anchor or mooring tension forces
- Monitor submersible test attachment forces

**SUBMERSIBLE S BEAM LOAD CELLS****Standard Product Specifications**

|  |  |
|--|--|
| Full Scale Capacity (FS)               | 100 to 20,000 lbf                                |
| Material <sup>1</sup>                  | 17-4 PH Stainless Steel                          |
| Nominal Output Signal at Capacity (FS) | 2.0 mV/V   |
| Optional Amplified Output <sup>2</sup> | 0 to 5 VDC, 0 to 10 VDC, 4 to 20 mA              |
| Combined Error                         | ≤ 0.35% of FS                                    |
| Zero Balance Signal                    | ≤ 1.00% of FS                                    |
| Input & Output Resistance <sup>3</sup> | 350 Ω Nominal                                    |
| Excitation Voltage                     | 2 to 24 V  |
| Insulation to Ground                   | > 5 GΩ   |
| Safe Overload                          | 150% of FS                                       |
| Ultimate Overload                      | 300% of FS                                       |
| Operating Depth                        | Customer Specified - Shallow Water Applications  |
| Sensor Material                        | 17-4 Stainless Steel                             |
| Electrical Connection <sup>4</sup>     | Integral 4 Conductor, 15' Long                   |
| Calibration                            | NIST Traceable per ASTM E4, Certificate Provided |

<sup>1</sup> Titanium, Aluminum, and others available

<sup>2</sup> Requires additional internal or external signal conditioning amplifier

<sup>3</sup> Options ranging from 120 Ω to 10,000 Ω available

<sup>4</sup> Optional custom connector or integral cable types & lengths available

Sensing Systems manufactures all submersible load cells to order and can customize almost all aspects of the product to meet the exact requirements of a specific application. If you are interested in discussing your application with an applications engineer, please contact us directly at [info@sensing-systems.com](mailto:info@sensing-systems.com) or (508) 992-0872.



**SUBMERSIBLE S BEAM LOAD CELLS**  
 Standard Product Outline Geometry - 100 to 20,000 lbf

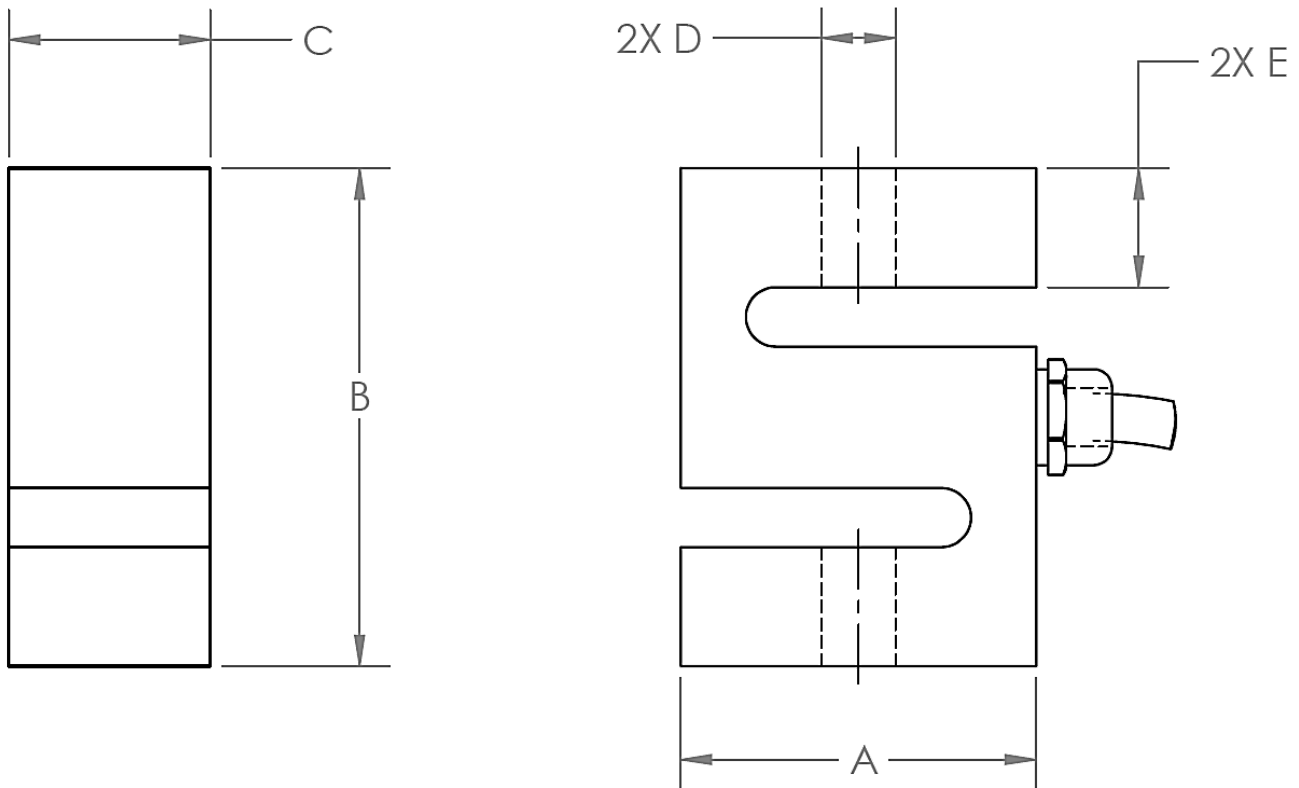

| Dimensions (inch)     | Full Scale Capacity (lbf) |         |         |         |         |           |
|-----------------------|---------------------------|---------|---------|---------|---------|-----------|
|                       | 100 to 300                | 500     | 1,000   | 5,000   | 10,000  | 20,000    |
| A - Overall Width     | 1.50                      | 1.50    | 1.75    | 3.00    | 3.25    | 4.25      |
| B - Overall Height    | 2.30                      | 2.30    | 2.50    | 3.95    | 5.00    | 6.90      |
| C - Overall Depth     | 0.85                      | 0.85    | 1.00    | 1.00    | 1.25    | 1.50      |
| D - Axial Thread      | ¼" - 28                   | ½" - 20 | ½" - 20 | ¾" - 16 | ¾" - 16 | 1-¼" - 12 |
| E - Thread Engagement | 0.50                      | 0.50    | 0.50    | 0.75    | 1.00    | 1.25      |



## **SUBMERSIBLE MULTI AXIS LOAD CELLS**

Virtually all types of “off the shelf” load cells and torque sensors can be made to operate underwater, including multi axis load cells. Forces and torques generated by equipment operating submerged, such as propellers or hydroelectric turbines, can be measured simultaneously using a submersible multi axis load cell. Please contact a Sensing Systems engineer directly with your application and we can propose a solution matched to your exact requirements.

## **SUBMERSIBLE TORQUE SENSORS**

### **REACTION TORQUE SENSORS**

Sensing Systems designs and manufactures submersible reaction torque sensors capable of measuring torques as small as 10 in-oz to as large as 300,000 in-lbs. Typically, reaction torque sensors are installed in line with existing motor, pump, or other assemblies. Please contact Sensing Systems with your existing size envelope, mating geometries, and full scale capacity and an engineer can propose a solution custom fit to your requirements.

### **ROTARY TORQUE SENSORS**

Depending on the application’s requirements, a submersible rotary torque sensor may be possible to design and manufacture. Variables such as operating speed, operating depth, and the overall assembly containing the torque sensor affect the feasibility of using a submerged rotating torque sensor. Please contact Sensing Systems directly and an engineer can advise on possible solutions.

## **CUSTOM SUBMERSIBLE & UNDERWATER SOLUTIONS**

Sensing Systems routinely manufactures submersible sensors designed to customer specified geometries, applications, and specifications. All sensors utilize the proven fundamental design techniques found in our standard product offerings. To discuss a custom application, please contact Sensing Systems directly with your request and general requirements. An engineer will work with you to propose a design specific to your application. If you are interested in discussing your application with an engineer, please contact us directly.



## TESTING SERVICES

### NIST Traceable Calibrations

Sensing Systems is accredited to ISO/IEC 17025:2017 and offers a full range of calibration services. At a minimum, all load cells and torque sensors are calibrated using NIST traceable standards per ASTM E4 or ASTM E264. Supplemental calibration or test data can be provided upon request. Additionally, all load cells and torque sensors undergo a 5 point electrical test prior to leaving the factory. All calibration and electrical data are provided on a calibration certificate shipped with each load cell or torque sensor. If required, calibrations may be performed in accordance with other industry standards or to customer specific requirements.

### Pressure Vessel Testing

Upon request, Sensing Systems can ensure functionality of sensors for deep water applications by pressure testing the finished product in a pressure vessel up to 10,000 psi. A standard pressure test consists of three runs from zero to maximum operating pressure and hold for thirty minutes. Output data vs. pressure data can be provided for applications requiring compensation for operation at large pressure differentials.

## SIGNAL CONDITIONING AMPLIFIER OPTIONS

All Sensing Systems force and torque sensors can be provided with an end of cable external signal conditioning amplifier. Typical amplified outputs include  $\pm 5$  VDC,  $\pm 10$  VDC, and 4 to 20 mA. When purchasing a sensor and amplifier together as a complete measurement system, both items are calibrated as a finished product to reduce overall measurement uncertainty.

### External Signal Conditioning Amplifier

A simple junction box housing a programmable signal conditioning amplifier can be purchased alongside all submersible load cells and torque sensors. The sensor cable free end terminates directly at the amplifier, which is typically housed near a data logger or monitoring location. The external amplifier is rated to IP67 and can be powered with 110/230 VAC or 18 to 24 VDC. The junction box comes with mounting holes and has the option of being mounted on a DIN rail.

### Internal Signal Conditioning Amplifier

When the application requires an amplified signal and space is tight, the option exists to house a miniature amplifier within the overall sensor geometry. In this case, all internal wiring terminates to the amplifier within the sensor and the mating cable provides a nominal supply voltage (VDC) to the amplifier and outputs the amplified signal.



## **ADDITIONAL INSTRUMENTATION & ACCESSORIES**

### **DIGITAL DISPLAY & READOUT OPTIONS**

All submersible sensors provided by Sensing Systems are designed to operate with digital displays. As an option, a dedicated display can be purchased with a submersible sensor. When purchased as a complete measurement system, both items are calibrated as a finished product to reduce overall measurement uncertainty. Options exist for displays capable of submersion or to output serial data directly to a PC connection. Please contact Sensing Systems directly to discuss your digital display requirements.

### **DIGITAL & SERIAL OUTPUT OPTIONS**

Optional modules for connecting to the load cell via USB, RS232, and RJ45 (ethernet) are available and can be configured to operate with all submersible sensors manufactured by Sensing Systems. Please contact us directly to discuss options for your particular application.